



## Main Features

- Modular design for flexible I/O expansion
- WLAN, 3G/LTE via 3 mini-PCIe + 1 M.2 slots
- Up to five SIM cards + triple WWAN modules support
- 6 x GbE 802.3 af/at PoE, 6 x M12 ports
- Built-in u-blox NEO-M8N module, optional dead reckoning support
- Intel® Core™ dual core i7-6600U/i3-6100U
- Dual removable SATA 3.0 2.5" SSD/HDD
- iButton for driver ID identification
- Built-in CAN 2.0B. Optional OBDII function (SAE J1939/J1708)

## Product Overview

MVS 5603-C6SMK 6-CH PoE In-vehicle mobile computer increases safety and security for bus passenger transportation with high video resolution and 2 removable extensive HDD/SSD and CFast for storage capacity. It connects up to 6 IP cameras + PoE function providing reliable and high quality video coverage around the bus.

MVS 5603-C6SMK is a modular design, it is flexible to use other kinds of expansion boards to extend different I/O functions for different applications.

MVS 5603-C6SMK leverages wireless networks to simplify fleet management with capabilities such as remote, real-time video monitoring. This remote capability keeps transit fleets in service around the clock.

Vehicle data integration and diagnostics are also carried out via CAN Bus and OBDII. MIL-STD-810G for shock and vibration is designed to operate in harsh environments. Optional internal back-up battery guards against any unexpected vehicle power failure or unstable vehicle power.

## Specifications

### CPU

- 6th Generation Intel® Core™ dual core i7-6600U, 2.6GHz/i3-6100U, 2.3GHz

### Memory

- 2-Channel 204-pin DDR3L SO-DIMM socket support 1600MHz up to 16GB, default 2GB industrial grade memory

### Storage

- 2 x 2.5" SATA 3.0 SSD/HDD (removable & hot swappable), RAID 0, 1 supported (optional lockable storage available)
  - 1 x CFast (externally accessible)

### Expansion

- 1 x Full size mini-PCIe socket (USB 2.0)
- 1 x Full size mini-PCIe socket (USB 2.0 + PCIe)
- 1 x Half size mini-PCIe socket (USB 2.0 + PCIe)
- 1 x M.2 B-key (3042)
- 1 x Full size mini-PCIe socket (USB 2.0)

### GNSS and On Board Sensor

- 1 x Default U-blox NEO-M8N GNSS module for GPS/Glonass/QZSS/Galileo/Beidou
- Optional modules with dead reckoning available
- Built-in G-sensor

### Power over Ethernet

- 6-Port M12 for 10/100/1000 Mbps PoE IEEE 802.3af/at conformity, total 60W PSE

### Security

- TPM in option

### I/O Interface-Front

- 6 x LED indicators for power/storage/WLAN/WWAN/status/health
- 1 x Reset button
- 2 x USB type A USB3.0 port
- 2 x Phone jacks 3.5mm for 1 x Mic-in and 1 x Line-out
- 1 x Externally accessible SIM card socket
- 2 x Antenna holes for WWAN/WLAN/BT/GPS

### I/O Interface-Rear

- 6 x M12 10/100/1000 Mbps PoE ports with LED
- 2 x RJ45 10/100/1000 Intel® Fast Ethernet with LED
- 1 x 9~36VDC input with ignition and 40W typical power consumption
- 2 x USB type A USB 3.0 port
- 2 x Phone jacks 3.5mm for 1 x Mic-in and 1 x Line-out
- 1 x DB-15 VGA, resolution up to 2560 x 1600 @60Hz
- 1 x HDMI port, resolution up to 2560 x 1600 @60Hz
- 2 x DB-9 RS-232

## Dimension Drawing

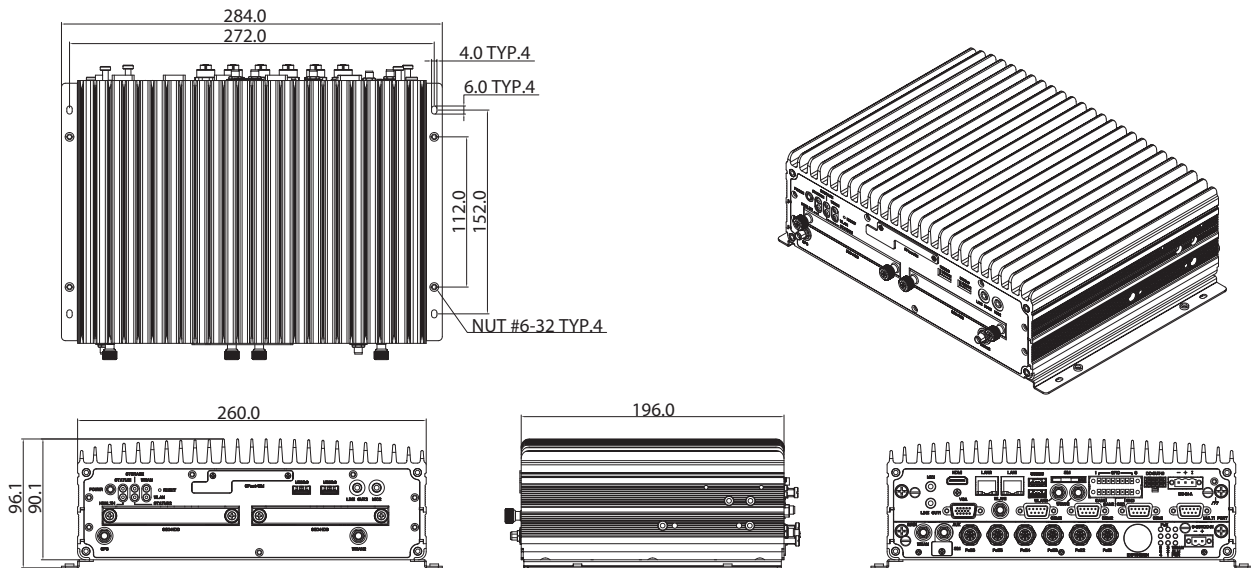

- 1 x DB-9 RS-232/422/485 (RI/5V/12V selectable)
- 1 x 12VDC output (2A) + SMBus + 2 x MDI + power button
- 1 x DB9 connector for optional DR signal input, 2 x MDO and iButton
- 1 x 16-Pin terminal block connector
  - 1 x CAN Bus 2.0B (on board)
  - 1 x OBDII from optional VIOB-CAN-03 module (SAE J1939)
  - 1 x CAN Bus 2.0B from optional VIOB-CAN-03 module
  - 8 x Programmable GPIO
    - (4 x Digital inputs in default)
      - Input voltage (source type): 5VDC TTL (default)
      - Input voltage (external type): 3~12VDC
    - (4 x Digital outputs in default)
      - Digital output (source type): 5VDC TTL (default), max current: 20mA
      - Digital output (external type): 3~24VDC, max current: 150mA
- 1 x Externally accessible SIM card socket and 1x internal SIM card socket selectable

### Power Management

- Selectable boot-up & shut-down voltage for low power protection by software. Setting 8-level power on/ off delay time by software. Support S3/S4 suspend mode

### Rechargeable Battery (option)

- Lithium-ion polymer
- Nominal capacity 1100mAh
- Maximum charge current 1.0CmA

### Operating System

- Windows 7/WES7/Windows 8/WES8/Windows 10/Linux kernel 3.X

### Dimensions

- 260mm (W) x 196mm (D) x 91mm (H) (10.24" x 7.72" x 3.58")
- 4kg

### Environment

- Operating temperatures:
  - 30°C~60°C (w/ industrial SSD) with air flow
- Storage temperatures: -40°C~80°C

- Relative humidity: 10% to 90% (non-condensing)
- Vibration (random):
  - 1.5g@5~500 Hz (in operation, HDD), 2g@5~500 Hz (in operation, SSD)
- Vibration (SSD):
  - Operating: MIL-STD-810G, Method 514.6C, Procedure 1, Category 4, common carrier US highway truck vibration exposure
  - Storage: MIL-STD-810G, Method 514.6E, Procedure 1, Category 24, minimum integrity test
- Shock (SSD/HDD):
  - Operating: MIL-STD-810G, Method 516.6, Procedure I, functional shock=20g (HDD); functional shock=40g (SSD)
  - Non-operating: MIL-STD-810G, Method 516.6, Procedure V, crash hazard shock test=75g

### Certifications

- CE approval, FCC Class A, E13 mark

## Ordering Information

- **MVS 5603-7C6SMK (P/N: 10VS0560304X0)**  
6th generation Intel® Core™ dual core i7-6600U, 2.6GHz, 2GB DDR3L industrial grade SO-DIMM, 6 x 10/100/1000 PoE, 2 x 10/100/1000 Ethernet, VGA/HDMI output, 2 x RS232, 1 x RS-232/422/485, 4 x USB 3.0, 12VDC output, 1 x CAN
- **MVS 5603-3C6SMK (P/N: 10VS0560303X0)**  
6th generation Intel® Core™ dual core i3-6100U, 2.3GHz, 2GB DDR3L industrial grade SO-DIMM, 6 x 10/100/1000 PoE, 2 x 10/100/1000 Ethernet, VGA/HDMI output, 2 x RS232, 1 x RS-232/422/485, 4 x USB 3.0, 12VDC output, 1 x CAN
- **Battery Kit (P/N: 88VS0560303X0)**  
Rechargeable battery, Lithium-ion, capacity 1100mAh